



TIRE REPAIR PRODUCTS



QUALITY WITHOUT COMPROMISE

www.Dura-Vulc.com
White Plains, New York, USA

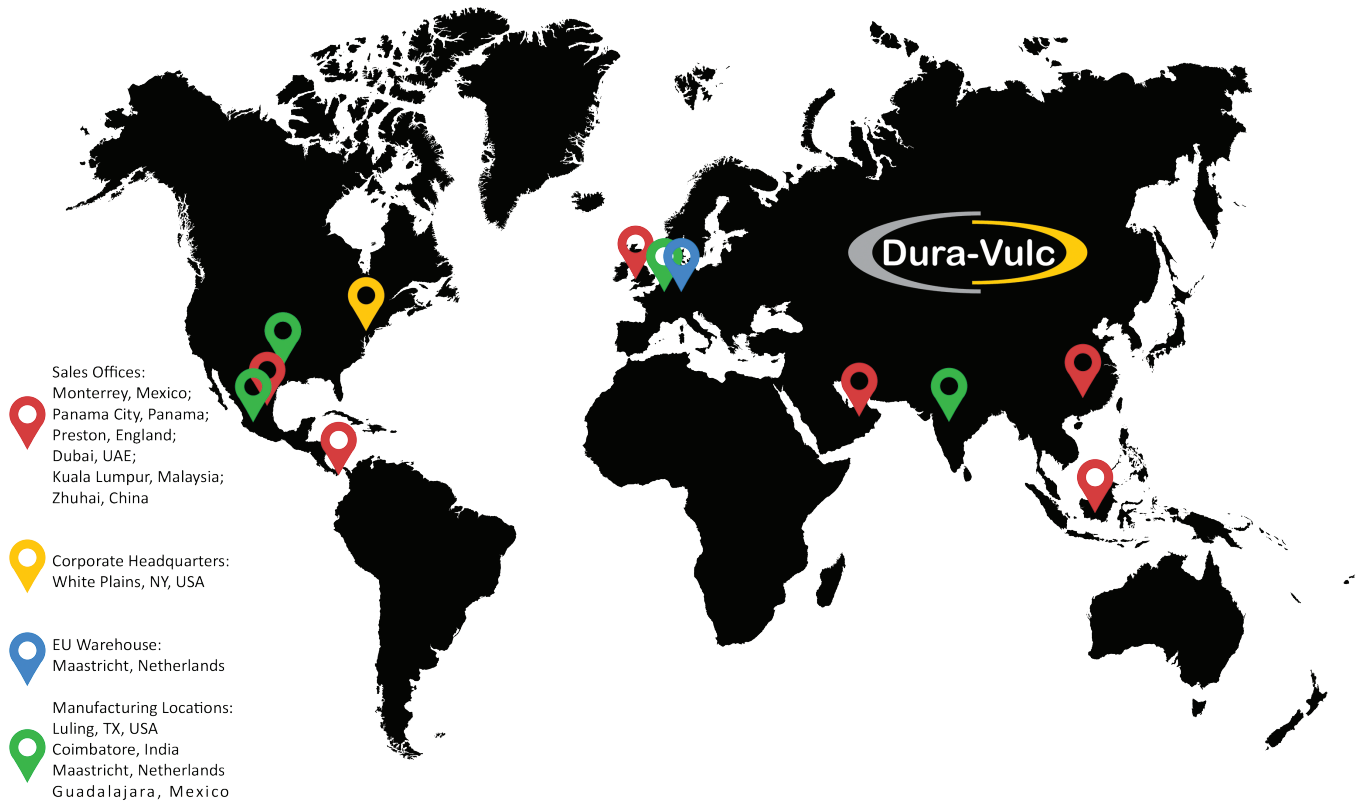

Headquartered in White Plains, New York, Dorian Drake International has been the world's leading supplier of USA-made tire repair string inserts for more than 20 years, supplying these products to many of the world's leading tire repair manufacturers and to independent tire repair products distributors under their house labels or the Dura Seal, Tire Seal, or Republic brands. Dorian Drake now introduces Dura-Vulc®, our own competitively priced proprietary brand of high quality tire repair string inserts, tire repair patches, cements, and tools that meets all US standards and specifications.

In addition, we represent several manufacturers that make products for the tire care industry, including the following:

- Ken-Tool tire changing tools
www.kentool.com
- ESCO - Equipment Supply Co. a line of tire-changing equipment
www.esco.net
- Dreumex hand cleaners, skin protection, and cleanser dispenser
www.dreumex.com/us/

The Dura-Vulc® brand is a registered CTM of Dorian Drake International, Inc.



TABLE OF CONTENTS

Tubeless Tire Repair Inserts	4	Kits	18
Permaseal Tire Repair	7	Tire Repair Tools	20
Soft Gum Patches (Uncured)	8	Tools and Accessories	21
Soft Gum Radial Repair	14	Patch Comparisons	22
Soft Gum Bias Repair	15	Notes	23
Vulcanizing Cement	16	Ken-Tool	24
Liquids and Sealants	17	Dreumex	25
		ESCO	26

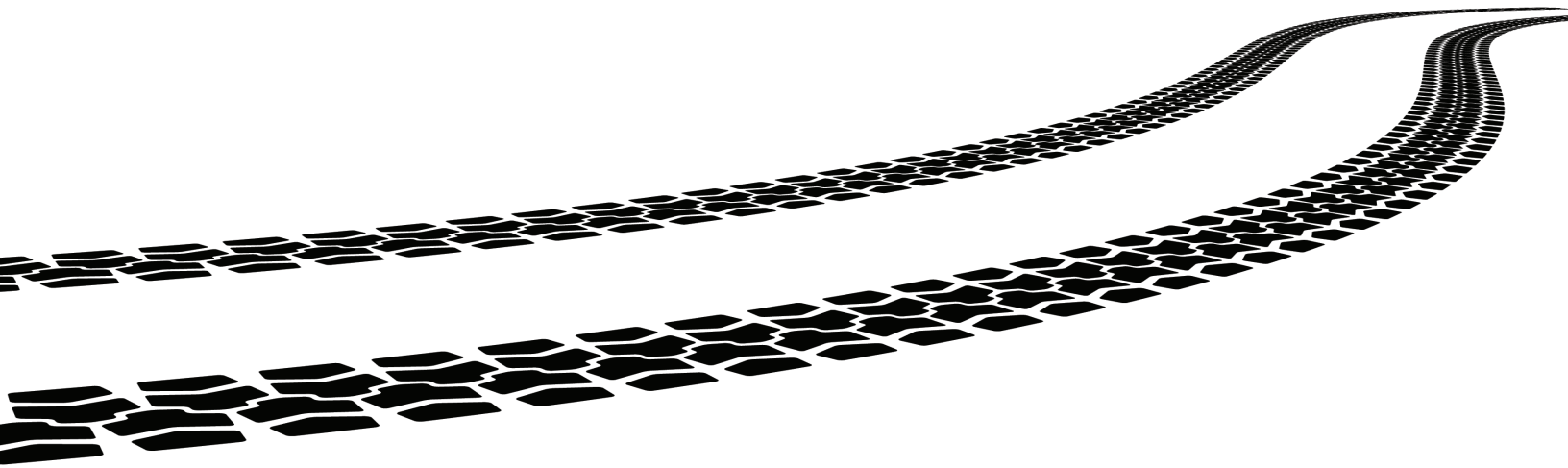

TUBELESS TIRE REPAIR INSERTS

“ON THE WHEEL REPAIR”

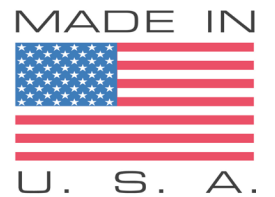

Tubeless tire repair strings, Instaseal, are Made in the USA to the highest industry standards at our facility in Texas. These compression inserts are designed for a multitude of applications. Use as a stand-alone temporary repair for cars and trucks. The insert becomes a permanent repair when used in conjunction with an inside repair unit. Excellent permanent repair for ATV's, golf carts, lawn and garden tires are available in a large variety of configurations such as:

- Length
- Color
- Thickness

as well as packaging options/sizes:

- **Bulk / Bagged.** Sheets packed in a bag
- **Box / no bags.** Sheets loose in a Dura-Vulc box
- **Box / bags.** Sheets packed in a bag inside Dura-Vulc box

Please specify your configuration for a custom quote. Note, minimum volume requirements apply for non-standard specifications.

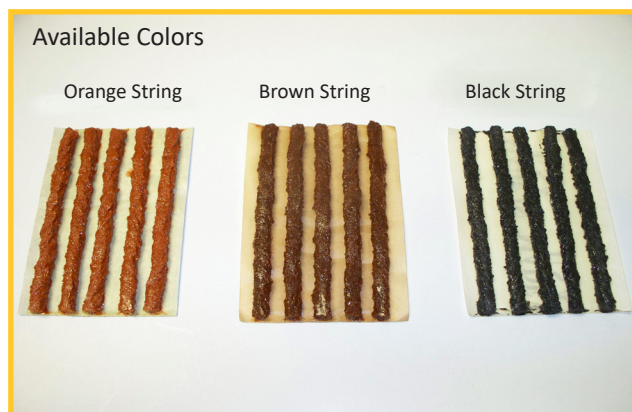

TUBELESS TIRE REPAIR INSERTS

PART #	PACKAGING	THICKNESS	LENGTH AND COLOR	STRINGS PER SHEET	SHEETS PER BAGS	# REPAIRS
BAGGED						
1-425-OR	Bagged; 25 String repairs	Standard Thickness 12 Strand	4" orange 12 strand repair	5	5	25
1-825-OR	Bagged; 25 String repairs	Standard Thickness 12 Strand	8" orange 12 strand repair	5	5	25
1-425-BR	Bagged; 25 String repairs	Standard Thickness 12 Strand	4" brown 12 strand repair	5	5	25
1-825-BR	Bagged; 25 String repairs	Standard Thickness 12 Strand	8" brown 12 strand repair	5	5	25
1-425-BL	Bagged; 25 String repairs	Standard Thickness 12 Strand	4" black 12 strand repair	5	5	25
1-825-BL	Bagged; 25 String repairs	Standard Thickness 12 Strand	8" black 12 strand repair	5	5	25
1-430-OR	Bagged; 30 String repairs	Standard Thickness 12 Strand	4" orange 12 strand repair	5	6	30
1-830-OR	Bagged; 30 String repairs	Standard Thickness 12 Strand	8" orange 12 strand repair	5	6	30
1-430-BR	Bagged; 30 String repairs	Standard Thickness 12 Strand	4" brown 12 strand repair	5	6	30
1-830-BR	Bagged; 30 String repairs	Standard Thickness 12 Strand	8" brown 12 strand repair	5	6	30
1-430-BL	Bagged; 30 String repairs	Standard Thickness 12 Strand	4" black 12 strand repair	5	6	30
1-830-BL	Bagged; 30 String repairs	Standard Thickness 12 Strand	8" black 12 strand repair	5	6	30
1-430-8-OR	Bagged; 30 String repairs	Thin 8 Strands	4" orange 8 strand repair	5	6	30
1-630-6-BL	Bagged; 30 String repairs	Thin 6 Strand	6" black 6 strand repair	5	6	30
1-725-5-BR	Bagged; 25 String repairs	Thin 5 Strand	7" brown 5 strand repair	5	5	25
1-725-6-BR	Bagged; 25 String repairs	Thin 6 Strand	7" brown 6 strand repair	5	5	25
1-925-8-BL	Bagged; 25 String repairs	Thin 8 Strands	9" black 8 strand repair	5	5	25
Non-Vulcanized						
1-750NV-5-BL	Bagged; 50 String repairs	Non Vulcanized Thin 5 Strand	7" black 5 strand repair nv	10	5	50
1-750NV-6-BL	Bagged; 50 String repairs	Non Vulcanized Thin 6 Strand	7" black 6 strand repair nv	10	5	50
PART #	BOX/NO BAG (Loose Sheets)	THICKNESS	LENGTH AND COLOR	STRINGS PER SHEET	SHEETS PER BOX	# REPAIRS
2-450-OR	Box, loose Sheets; 50 string repairs	Standard Thickness 12 Strand	4" orange 12 strand repair	5	10	50
2-450-BR	Box, loose Sheets; 50 string repairs	Standard Thickness 12 Strand	4" brown 12 strand repair	5	10	50
2-450-BL	Box, loose Sheets; 50 string repairs	Standard Thickness 12 Strand	4" black 12 strand repair	5	10	50
2-825-OR	Box, loose Sheets; 25 string repairs	Standard Thickness 12 Strand	8" orange 12 strand repair	5	5	25
2-825-BR	Box, loose Sheets; 25 string repairs	Standard Thickness 12 Strand	8" brown 12 strand repair	5	5	25
2-825-BL	Box, loose Sheets; 25 string repairs	Standard Thickness 12 Strand	8" black 12 strand repair	5	5	25
2-460-OR	Box, loose Sheets; 60 string repairs	Standard Thickness 12 Strand	4" orange 12 strand repair	5	12	60
2-460-BR	Box, loose Sheets; 60 string repairs	Standard Thickness 12 Strand	4" brown 12 strand repair	5	12	60
2-460-BL	Box, loose Sheets; 60 string repairs	Standard Thickness 12 Strand	4" black 12 strand repair	5	12	60
2-830-OR	Box, loose Sheets; 30 string repairs	Standard Thickness 12 Strand	8" orange 12 strand repair	5	6	30
2-830-BR	Box, loose Sheets; 30 string repairs	Standard Thickness 12 Strand	8" brown 12 strand repair	5	6	30
2-830-BL	Box, loose Sheets; 30 string repairs	Standard Thickness 12 Strand	8" black 12 strand repair	5	6	30
2-460-8-OR	Box, loose Sheets; 60 string repairs	Thin 8 Strand	4" orange 8 strand repair	5	12	60
2-630-6-BL	Box, loose Sheets; 30 string repairs	Thin 6 Strand	6" black 6 strand repair	5	6	30
2-750-5-BR	Box, loose Sheets; 50 string repairs	Thin 5 Strand	7" brown 5 strand repair	5	10	50
2-725-6-BR	Box, loose Sheets; 25 string repairs	Thin 6 Strand	7" brown 6 strand repair	5	5	25
2-925-8-BL	Box, loose Sheets; 25 string repairs	Thin 8 Strand	9" black 8 strand repair	5	5	25
2-1250-8-BR	Box, loose Sheets; 50 string repairs	Thin 8 Strand	12" brown 8 strand repair	5	10	50
2-1220-6-BL	Box, loose Sheets; 20 string repairs	Thin 6 Strand	12" black 6 strand repair	5	4	20

CONTINUED ON NEXT PAGE...

TUBELESS TIRE REPAIR INSERTS

PART #	PACKAGING	THICKNESS	LENGTH AND COLOR	STRINGS PER SHEET	SHEETS PER BAG OR BOX	# OF REPAIRS
BAG IN BOX						
4-440-OR	Bag in Box; 40 strings repairs	Standard Thickness 12 Strand	4" orange 12 strand repair	5	8	40
4-440-BR	Bag in Box; 40 strings repairs	Standard Thickness 12 Strand	4" brown 12 strand repair	5	8	40
4-440-BL	Bag in Box; 40 strings repairs	Standard Thickness 12 Strand	4" black 12 strand repair	5	8	40
4-450-OR	Bag in Box; 50 strings repairs	Standard Thickness 12 Strand	4" orange 12 strand repair	5	10	50
4-450-BR	Bag in Box; 50 strings repairs	Standard Thickness 12 Strand	4" brown 12 strand repair	5	10	50
4-450-BL	Bag in Box; 50 strings repairs	Standard Thickness 12 Strand	4" black 12 strand repair	5	10	50
4-820-OR	Bag in Box; 20 strings repairs	Standard Thickness 12 Strand	8" orange 12 strand repair	5	4	20
4-820-BR	Bag in Box; 20 strings repairs	Standard Thickness 12 Strand	8" brown 12 strand repair	5	4	20
4-820-BL	Bag in Box; 20 strings repairs	Standard Thickness 12 Strand	8" black 12 strand repair	5	4	20
4-825-OR	Bag in Box; 25 strings repairs	Standard Thickness 12 Strand	8" orange 12 strand repair	5	5	25
4-825-BR	Bag in Box; 25 strings repairs	Standard Thickness 12 Strand	8" brown 12 strand repair	5	5	25
4-825-BL	Bag in Box; 25 strings repairs	Standard Thickness 12 Strand	8" black 12 strand repair	5	5	25
4-460-OR	Bag in Box; 60 strings repairs	Standard Thickness 12 Strand	4" orange 12 strand repair	5	12	60
4-460-BR	Bag in Box; 60 strings repairs	Standard Thickness 12 Strand	4" brown 12 strand repair	5	12	60
4-460-BL	Bag in Box; 60 strings repairs	Standard Thickness 12 Strand	4" black 12 strand repair	5	12	60
4-830-OR	Bag in Box; 30 strings repairs	Standard Thickness 12 Strand	8" orange 12 strand repair	5	6	30
4-830-BR	Bag in Box; 30 strings repairs	Standard Thickness 12 Strand	8" brown 12 strand repair	5	6	30
4-830-BL	Bag in Box; 30 strings repairs	Standard Thickness 12 Strand	8" black 12 strand repair	5	6	30
4-460-8-OR	Bag in Box; 60 strings repairs	Thin 8 Strand	4" orange 8 strand repair	5	12	60
4-460-8-BR	Bag in Box; 60 strings repairs	Thin 8 Strand	4" brown 8 strand repair	5	12	60
4-460-8-BL	Bag in Box; 60 strings repairs	Thin 8 Strand	4" black 8 strand repair	5	12	60
4-630-6-BL	Bag in Box; 30 strings repairs	Thin 6 Strand	6" black 6 strand repair	5	6	30
4-725-5-BR	Bag in Box; 25 strings repairs	Thin 5 Strand	7" brown 5 strand repair	5	5	25
4-725-6-BR	Bag in Box; 25 strings repairs	Thin 6 Strand	7" brown 6 strand repair	5	5	25
4-925-8-BL	Bag in Box; 25 strings repairs	Thin 8 Strand	9" black 8 strand repair	5	5	25
Non-Vulcanized						
4-750NV-5-BL	Bag in Box; 50 strings repairs	Non Vulcanized Thin 5 Strand	7" black 5 strand repair nv	10	5	50
4-750NV-6-BL	Bag in Box; 50 strings repairs	Non Vulcanized Thin 6 Strand	7" black 6 strand repair nv	10	5	50
PART #	MISCELLANEOUS PACKAGING	THICKNESS	LENGTH, COLOR, AND TYPE OF BOX	STRINGS PER SHEET	SHEETS PER BOX	TOTAL # REPAIRS
3-174	Box, loose Sheets; 50 string repairs	Standard Thickness 12 Strand	4" 12 strand "match box" Slider Box-P/M	5	10	50
3-175	Box, loose Sheets; 50 string repairs	Standard Thickness 12 Strand; Mylar on Mylar	4" 12 strand "match box" Slider Box-M/M	5	10	50
3-176	Box, loose Sheets; 280 string repairs	Standard Thickness 12 Strand	4" 12 strand Hanging Box P/M	5	56	280
3-177	Box, loose Sheets; 280 string repairs	Standard Thickness 12 Strand; Mylar on Mylar	4" 12 strand Hanging Box M/M	5	56	280

PERMASEAL TIRE REPAIR

PermaSeal Vulcanizing Insert

The PermaSeal- Vulcanizing Repair Insert may be used as a stem insert when used for angle and straight injuries with a repair unit or as a stand-alone insert to repair a tire. The vulcanizing facing gum rubber of the insert, when used in conjunction with the Dura-Vulc chemical vulcanizing cement creates a permanent vulcanized bond to the tire. It is the preferred insert of tire professionals because of this unique chemical vulcanizing characteristic that most ordinary tire plug inserts don't have.



PART #	PACKAGING	THICKNESS	LENGTH AND COLOR	REPAIRS/ BAG	TOTAL # REPAIRS
BAGGED - Individual Repairs					
3-104	50 Repairs in a bag	Thin Blue Poly wrap	3 3/4" black 8 strand rep/blue poly	50	50
3-105	50 Repairs in a bag	Standard Red Poly wrap	3 3/4" black 10 strand rep/red poly	50	50
3-106	50 Repairs in a bag	Thin Blue Poly wrap	5 1/2" black 8 strand rep/blue poly	50	50
3-107	50 Repairs in a bag	Standard Red Poly wrap	5 1/2" black 10 strand rep/red poly	50	50
3-108	25 Repairs in a bag	Thin Blue Poly wrap	8" black 8 strand rep/blue poly	25	25
3-109	25 Repairs in a bag	Standard Red Poly wrap	8" black 10 strand rep/red poly	25	25
BOX (No Bag) - Individual Repairs					
3-124	50 Repairs in a box	Thin Blue Poly wrap	3 3/4" black 8 strand rep/blue poly	50	50
3-125	50 Repairs in a box	Standard Red Poly wrap	3 3/4" black 10 strand rep/red poly	50	50
3-126	50 Repairs in a box	Thin Blue Poly wrap	5 1/2" black 8 strand rep/blue poly	50	50
3-127	50 Repairs in a box	Standard Red Poly wrap	5 1/2" black 10 strand rep/red poly	50	50
3-128	25 Repairs in a box	Thin Blue Poly wrap	8" black 8 strand rep/blue poly	25	25
3-129	25 Repairs in a box	Standard Red Poly wrap	8" black 10 strand rep/red poly	25	25
BAG in BOX - Individual Repairs					
3-114	50 Repairs in a bag in box	Thin Blue Poly wrap	3 3/4" black 8 strand rep/blue poly	50	50
3-115	50 Repairs in a bag in box	Standard Red Poly wrap	3 3/4" black 10 strand rep/red poly	50	50
3-116	50 Repairs in a bag in box	Thin Blue Poly wrap	5 1/2" black 8 strand rep/blue poly	50	50
3-117	50 Repairs in a bag in box	Standard Red Poly wrap	5 1/2" black 10 strand rep/red poly	50	50
3-118	25 Repairs in a bag in box	Thin Blue Poly wrap	8" black 8 strand rep/blue poly	25	25
3-119	25 Repairs in a bag in box	Standard Red Poly wrap	8" black 10 strand rep/red poly	25	25

SOFT GUM PATCHES (UNCURED)

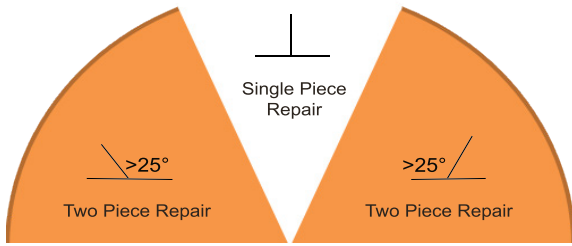

Stem-Patch Combination Repair Unit

Stem-patches are the ultimate tire repair of choice for quality high performance standard automobile to commercial truck tires. The Stem Patch offers a vulcanizing rubber stem and cap unit that vulcanizes to both the injury and the inner liner of the tire for straight through punctures and injuries up to 25 degree off centre. Utilizing a rubber reinforced body that vulcanizes to the tires inner liner combined with a vulcanizing rubber stem that bonds around the injury, performing an air tight seal around the stem plug.



Stem Insert Only - Soft Gum with Lead Wire

For bias and radial tires. Metal stem allows for easy insertion. Stem is wrapped with grey gum, and vulcanizes with chemical vulcanizing cement to the injury.



PART #	PRODUCT CODE	STEM DIAMETER Ø		INJURY SIZE Ø		CARBIDE CUTTER	QTY/BOX	BOXES/CASE
		MM	INCH	MM	INCH			
3-006SI	SI 06 W	7.2	9/32	6	1/4	4.5 mm	20	390
3-008SI	SI 08 W	9.6	3/8	8	5/16	6 mm	20	297
3-010SI	SI 10 W	12	15/32	10	3/8	8 mm	20	168
3-013SI	SI 13 W	16	5/8	13	1/2	10 mm	10	178
3-020SI	SI 20 W	24	15/16	20	3/4		10	66
3-025SI	SI 25 W	30	1 3/16	25	1		10	42

Injury penetration angle exceeds 25°, use the stem insert. To be reinforced with suitable repair unit.

SOFT GUM PATCHES (UNCURED)

Stem Patch - Soft Gum with Lead Wire

For bias and radial tires. Metal stem cover allows for easy insertion. Grey gum on the cap and stem vulcanizes with chemical vulcanizing cement to the inner liner and the injury.

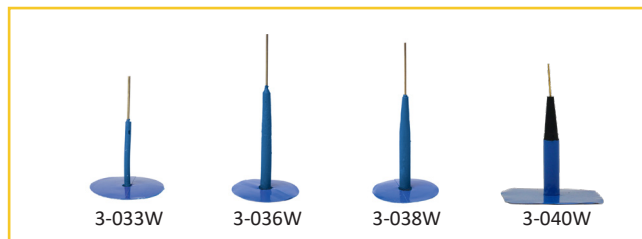

PART #	PRODUCT CODE	STEM Ø		REPAIR UNIT Ø		INJURY SIZE Ø		USE CARBIDE CUTTER	QTY/BOX	BOXES/CASE
		MM	INCH	MM	INCHES	MM	INCH			
3-033W	SP 03 W	3.6	9/64	35	1 3/8	3	1/8	3 mm	24	96
3-036W	SP 06 W	7.2	9/32	55	2 1/64	6	1/4	4.5 mm	24	18
3-038W	SP 08 W	9.6	3/8	65	2 9/16	8	5/16	6 mm	24	18
3-040W	SP 10 W	12	15/32	80x80 sq	35/32 X 35/32	10	3/8	8 mm	10	18
3-043R	SP B 13 R	16	5/8	150x150 oc	5 29/32 X 3 29/32	13	1/2	10 mm	6	12
3-050R	SP B 20 R	24	15/16	170x170 oc	6 1/16 X 6 1/16	20	3/4		6	12
3-040RR	SP 10 RR	30	1 3/16	80x80 sq	35/32 X 35/32	25	1		10	18

Injury penetration angle within 25°, use the stem repair units.

Stem Patch - Soft Gum with Quill

For bias and radial tires. Quill cover allows for easy insertion. Grey gum on the cap only vulcanizes with chemical vulcanizing cement to the inner liner

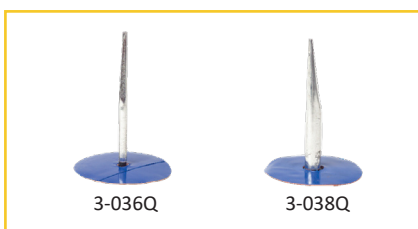

PART #	PRODUCT CODE	STEM Ø		REPAIR UNIT Ø		INJURY SIZE Ø		CUTTER SIZE	QTY/BOX	BOXES/CASE
		MM	INCHES	MM	INCHES	MM	INCHES			
3-036Q	SP 06 Q	7.2	9/32	55	2 1/64	6	1/4	4.5 mm	24	18
3-038Q	SP 08 Q	9.6	3/8	65	2 9/16	8	5/16	6 mm	24	18

Injury penetration angle within 25°, use the stem repair units.

SOFT GUM PATCHES (UNCURED)

Universal Repair Unit

The Dura-Vulc Universal Repair was developed for use in both radial and bias applications as well as tube or tubeless tire constructions. This repair concept provides added strength over a rubber reinforced repairs unit because of its special woven fabric ply that provides strength and multi universal direction control when applied to the tire. This repair choice offers premium quality strength in a multi directional choice. The Universal repair is an excellent repair choice when repairing tire where reinforcement ply is required.



PART #	PRODUCT CODE	REPAIR UNIT Ø		INJURY SIZE Ø		RECOMMENDED STEM INSERT	QTY / BOX	BOXES / CASE
		MM	INCHES	MM	INCH			
3-301	UP C 45	45	1 ¾	3	1/8		30	500
3-305	UP C 60	60	2 ¾	6	1/4	SI 06 W	25	320
3-306	UP C 75	75	3	8	5/16	SI 08 W	20	216
3-307	UP C 90	90	3 ½	10	3/8	SI 10 W	10	150
3-314	UP S 75	75x75	3x3	8	5/16	SI 08 W	30	144

All Purpose Repair Unit

All Purpose Rubber Reinforced Repair all purpose rubber reinforced repair units are for use in virtually any application. Can be used with Radial tire, and with Bias tires when reinforced with a stem insert to fill the injury. The all-purpose repair has an extra thick gauge of rubber reinforcement to provide a combination of flexibility with durability for bias and radial tube type or tubeless tires and can be used on all type of inner tubes.

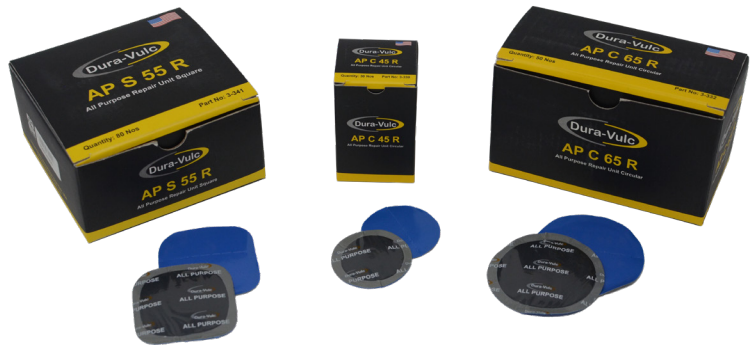

PART #	PRODUCT NAME	REPAIR UNIT Ø		INJURY SIZE Ø				RECOMMENDED STEM INSERT	QTY / BOX	BOXES / CASE
				TUBE INJURY		PASSENGER / LT TIRE INJURY				
		MM	INCHES	MM	INCHES	MM	INCH	INCHES		
3-330	AP C 45 R	45	1 ¾	20	3/4	3	1/8	SI 06W	30	400
3-331	AP C 55 R	55	2 1/64	30	1 3/16	3	1/8	SI 06W	30	192
3-332	AP C 65 R	65	2 5/16	40	1 ½	6	1/4	SI 08 W	50	98
3-340	AP S 45 R	45	1 ¾	20	3/4	3	1/8	SI 06W	100	125
3-341	AP S 55 R	55	2 1/64	30	1 3/16	3	1/8	SI 06W	80	80
3-342	AP S 65 R	65	2 5/16	40	1 ½	6	1/4	SI 08 W	25	196

SOFT GUM PATCHES (UNCURED)

Radial Repair

Units are constructed of the highest quality rubber compound. This ensures the high flexibility in compound and design. Each radial repair unit has a flexible “shock absorbing” ply of rubber to withstand the flexing associated with a radial constructed tire. This unit will work with both tube and tubeless tire constructions. The strong tensile strength of the fabric ply is to replace the structural integrity of the tire. The top cover stock of the repair unit is then molded in place to anchor and protect the plies. These repairs are manufactured with the chemical vulcanizing facing gum to permanently vulcanize and bond to the tire’s inner liner.



PART #	PRODUCT CODE	REPAIR UNIT SIZE		QTY/BOX	BOXES/CASE
		MM	INCHES		
3-260	RD 110	70 x 50	2 ½ x 2	20	300
3-260R	RD 110 R	80 x 60	3 ⅞ x 2 ⅜	10	294
3-261	RD 112	110 x 65	4 ⅜ x 2 ½	10	288
3-261R	RD 112 R	70 x 115	2 ¾ x 4 ⅜	10	196
3-262	RD 114	330 x 125	13 x 5 ⅜	10	144
3-263	RD 120	130 x 80	5 ⅞ x 3 ⅞	10	168
3-264	RD 122	175 x 80	6 ¾ x 3 ⅜	10	108
3-265	RD 124	210 x 85	8 ¼ x 3 ⅜	10	84
3-266	RD 126	250 x 75	10 x 3	10	72
3-267	RD 128	250 x 75	13 ⅞ x 2 ½	10	48
3-268	RD 133	125 x 100	5 x 4	10	100
3-269	RD 135	150 x 125	6 x 5	10	48
3-270	RD 137	170 x 125	6 ¾ x 5	5	108
3-271	RD 140	200 x 100	8 x 4	10	60
3-272	RD 142	250 x 125	10 x 5	5	80
3-273	RD 144	250 x 125	10 x 5	5	40
3-274	RD 146	405 x 140	16 x 5 ½	5	21
3-274	RD 146	405 x 140	16 x 5 ½	5	21
3-279	RD 180	150 x 195	6 x 7 ¾	5	63
3-280	RD 182	190 x 250	7 ½ x 10	5	24
3-281	RD 184	215 x 290	8 ½ x 11 ½	5	16
3-282	RD 186	245 x 340	9 ¾ x 13 ½	5	16



SOFT GUM PATCHES (UNCURED)

Bias Repairs

Units are designed with a crisscross diagonal ply construction. It has a built in rubber shock absorbing ply to withstand the rolling impact and provide strength and flexibility of the bias tire design. This repair design will perform in both tube and tubeless tire constructions.

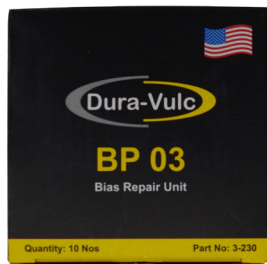

PART #	PRODUCT CODE	REPAIR UNIT SIZE		QTY/BOX	BOXES/CASE
		MM	INCHES		
3-230	BP03	100	4	10	150
3-232	BP04H	130	5 ¼	10	36
3-234	BP05	165	6 ¼	10	36
3-235	BP06	240	9 ¾	5	24
3-236	BP07	290	11 ½	5	6
3-237	BP08	340	13 ¾	5	6
3-238	BP09	380	15 ¼	3	8
3-239	BP10	430	17	3	9
3-240	BP20	200	8	10	16
3-241	BP21	225	9	5	24
3-242	BP22	275	11	5	6
3-243	BP23	375	15	5	7
3-244	BP24	225	9	5	24
3-245	BP25	275	11	5	6
3-246	BP26	375	15	5	7
3-248	BP42	300	12	12	2
3-249	BP46	400	16	6	4
3-252	BP61	180	7 ¼	10/Box	1

SOFT GUM PACTHES (UNCURED)



Tube Repair Circular - Soft Gum

PART #	PRODUCT CODE	REPAIR UNIT Ø		QTY / BOX	BOXES/ CASE
		MM	INCHES		
3-350	CT 25	25	1	140	648
3-360	CT 35	35	1 3/8	50	546
3-352	CT 45	45	1 3/4	40	400
3-354	CT 60	60	2 3/8	30	320
3-356	CT 80	80	3 1/2	20	288
3-357	CT 100	100	4	20	200
3-359	CT 125	125	5	10	272

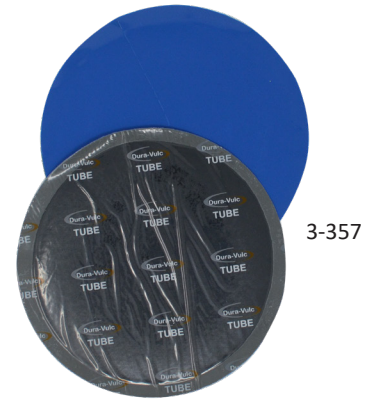

Tube Repairs Oval - Soft Gum

PART #	PRODUCT CODE	REPAIR UNIT Ø		QTY/BOX	BOXES/ CASE
		MM	INCHES		
3-362	OT 40	40 x 30	1 37/64 x 1 3/16	100	384
3-367	OT 65	65 x 40	2 9/16 x 1 37/64	30	294
3-364	OT 100	100 x 50	3 15/16 x 1 31/32	20	360
3-365	OT 150	150 x 70	5 29/32 x 2 3/4	20	189
3-366	OT 160	160 x 100	6 19/34 x 3 15/16	10	255

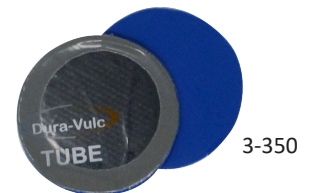
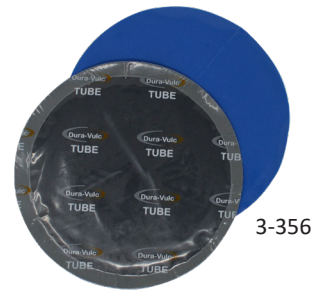

Soft Gum Radial Repair Chart

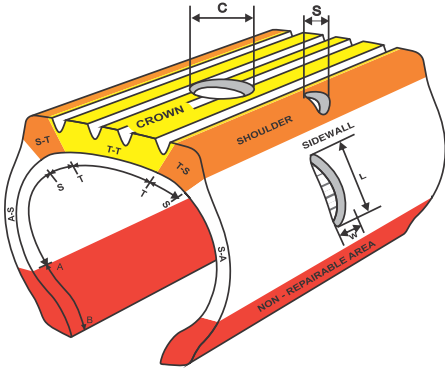

Legend	
A-B	Non-Repairable Area
S-A	Sidewall
S-T	Shoulder
T-T	Crown
C	Diameter of injury
S	Diameter of injury
L	Length of injury
W	Width of injury

Repair Restriction		
Section Width	Non-Repairable Area (A-B)	Shoulder (S-T)
Passenger Tyres	1-1/2" (40 mm)	1" (25 mm)
	6.50-7.00 (165-195)	2-1/2" (65 mm)
7.50-16.00 (190-385)	3" (75 mm)	1-1/2" (40 mm)
17.50-23.50 (425-600)	3-1/2" (90 mm)	

The above dimension are only guidelines.



Crown (T-T) Diameter	Shoulder (S-T) Diameter	Sidewall (S-A)		Speed Rating ≤U
		Width	Length	
1/4" (6 mm)	1/4" (6 mm)	RD110		
		RD114		
		1/4" (6 mm)	1/2" (13 mm)	
		3/8" (10mm)	2" (50 mm)	
3/8" (10 mm)	3/8" (10 mm)	RD110R		
		RD114		
		3/8" (10 mm)	1-1/2" (40 mm)	
		3/8" (10 mm)	2" (50 mm)	
1/2" (13 mm)	1/2" (13 mm)	RD112R		
		RD114		
		1/2" (13 mm)	1-1/2" (40 mm)	
		1/2" (13 mm)	2" (50 mm)	
3/4" (20 mm)	3/4" (20 mm)	RD112R		
		RD114		
		3/4" (20 mm)	1-1/2" (40 mm)	
		3/4" (20 mm)	2" (50 mm)	
1" (25 mm)	1" (25 mm)	RD114		
		RD114		
		1" (25 mm)	1-1/2" (40 mm)	
		1" (25 mm)	2" (50 mm)	

Notes for Passenger Tyres:

Tyres with speed rating of H, V, W, Y or Z are repairable in the crown area (T-T) but should not exceed 1/4" (6 mm) or one injury per tyre in order to maintain their designated speed rating. Run Flat Tyres maintain the same limitation as the performance tyre except multiple nail hole repairs may be performed unless it is in the same radial cord or where repair units overlap. Performance tyres are repairable beyond the shoulder area, but the speed rating would be reduced below H rating.

Repair Unit Size	Dimensions		Ply Rating
	mm	Inches	
RD110	70 x 50	2-3/4 x 2	1
RD110R	80 x 60	3-1/4 x 2-3/8	1
RD112	110 x 60	2-3/4 x 4-5/8	1
RD112R	115 x 70	4-3/8 x 2-3/8	1
RD114	145 x 75	5-3/4 x 3	1
RD120	125 x 75	5 x 3	2
RD122	165 x 75	6-1/2 x 3	2
RD124	215 x 75	8-1/2 x 3	2
RD126	250 x 75	10 x 3	3
RD128	375 x 75	13-1/8 x 2-1/8	3
RD122S	165 x 75	6-1/2 x 3	1
RD124S	215 x 75	8-1/2 x 3	1
RD126S	250 x 75	10 x 3	1
RD128S	325 x 75	12-3/4 x 3	1
RD133	125 x 100	5 x 4	3
RD135	150 x 125	6 x 5	4
RD137	170 x 125	6-3/4 x 5	4
RD140	200 x 100	8 x 4	3
RD142	250 x 125	10 x 5	3
RD144	330 x 125	13 x 5	4
RD146	405 x 140	16 x 5-1/2	4



Crown (T-T) Diameter	Shoulder (S-T) Diameter	Sidewall (S-A)		Light Truck Load Range ≤E	Truck & Bus Tyre Size			
		Width	Length		6.50-12.50	7.50-10.00	11.00-14.00	15.00-17.50
1/8" (3 mm)	1/8" (3 mm)	RD110		LT 215 - 285	8-11 235/80 - 275/80 225/75 - 295/75	12-16.5 295/80	315-80 495/65 425/50 - 495/45	
		RD110R	RD110R	RD110R	RD110R			
1/4" (6 mm)	1/4" (6 mm)	RD110		RD110	RD120	RD120	RD120	
		RD110R	RD110R	RD110R	RD110R			
5/16" (8 mm)	5/16" (8 mm)	RD110		RD110	RD120	RD120	RD120	
		RD110R	RD110R	RD110R	RD110R			
3/8" (10 mm)	3/8" (10 mm)	RD110		RD110	RD120	RD120	RD120	
		RD110R	RD110R	RD110R	RD110R			
1/2" (13 mm)	1/2" (13 mm)	RD110		RD110	RD120	RD120	RD120	
		RD110R	RD110R	RD110R	RD110R			
3/4" (20 mm)	3/4" (20 mm)	RD110		RD110	RD120	RD120	RD120	
		RD110R	RD110R	RD110R	RD110R			
1" (25 mm)	1" (25 mm)	RD110		RD110	RD120	RD120	RD120	
		RD110R	RD110R	RD110R	RD110R			
1-1/4" (32 mm)	1-1/4" (32 mm)	RD110		RD110	RD120	RD120	RD120	
		RD110R	RD110R	RD110R	RD110R			

Note: Repair unit mentioned for H, V, W, Y or Z are limited to (T-T) crown area only. All other repair unit mentioned for section repair can be used for crown or sidewall injuries. For (S-T) shoulder area up to 3/8" (10mm) injury use RS - Radial shoulder repair only. Repair on Performance tyre should not exceed or supersede limitation of the new tyre manufacturer's recommendations. All injuries should be filled and supported with the appropriate repair unit. Load, speed and highway application condition may affect section repairs. This selection repair chart is to be used only as a guide.

FCI-UK-00/00-00

Soft Gum Bias Repair Chart

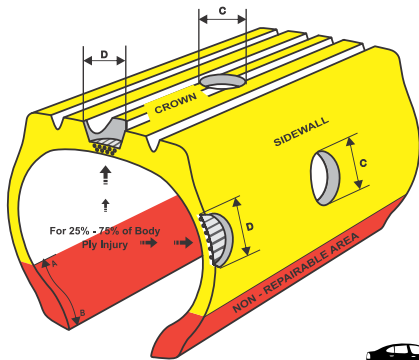

Legend	
A-B	Non-Repairable Area
C	Diameter of Injury
D	25% - 75% of Body ply Diameter of Injury

Repair Restriction	
Section Width	Non-Repairable Area (A-B)
Passenger Tyres	1 1/2" (40mm)
LT up to 7.50 (195mm)	3 1/4" (80mm)
8.25 (205mm) to 14.00 (355mm)	4" (100mm)

The above dimension are only guidelines.

TO DETERMINE SUITABLE REPAIR UNIT:

For proper repair unit selection, determine the size of the injury in the tyre by measuring largest cord area removed. Locate the correct injury size along the top row of the chart then locate the tyre's ply rating (load range) along the left column of the same chart. The repair unit size shown in the box where these intersect is the recommended repair unit to use.



Ply Rating / Load Range	Maximum Injury Size - C								
	1/8" (3 mm)	1/4" (6 mm)	3/8" (10 mm)	1/2" (15 mm)	3/4" (20 mm)	1" (25 mm)	1-1/2" (40 mm)	2" (50 mm)	2-1/2" (65 mm)
4 / B	RC55	RC55	RC80	BP03	BP03	BP03	BP04	BP05	-
6 / C	RC55	RC55	RC80	BP03	BP03	BP03	BP04	BP05	BP06
8 / D	RC55	RC80	RC80	BP03	BP03	BP04	BP04	BP05	BP06



Ply Rating / Load Range	Maximum Injury Size - C											
	1/8" (3 mm)	1/4" (6 mm)	3/8" (10 mm)	1/2" (15 mm)	3/4" (20 mm)	1" (25 mm)	1-1/2" (40 mm)	2" (50 mm)	2-1/2" (65 mm)	3" (75 mm)	4" (100 mm)	5" (125 mm)
8 / D	RC55	RC55	RC80	BP03	BP03	BP04	BP04	BP05	BP06	-	-	-
10 / E	RC55	RC80	RC80	BP03	BP03	BP04	BP05	BP06	BP06	BP07	BP08	-
12 / F	RC55	RC80	RC80	BP04	BP04	BP04	BP05	BP06	BP06	BP07	BP08	-
14 / G	RC55	RC80	BP03	BP04	BP04	BP05	BP06	BP06	BP07	BP07	BP08	BP10
16 / H	RC55	RC80	BP04	BP04	BP05	BP05	BP06	BP06	BP07	BP07	BP08	BP10
18 / J	RC55	RC80	BP04	BP05	BP05	BP06	BP06	BP07	BP08	BP08	BP09	BP10
20 / L	RC55	RC80	BP04	BP05	BP05	BP06	BP07	BP08	BP08	BP09	BP09	BP10



Ply Rating / Load Range	Maximum Injury Size - D										
	1/4" (6 mm)	3/8" (10 mm)	1/2" (15 mm)	3/4" (20 mm)	1" (25 mm)	1-1/2" (40 mm)	2" (50 mm)	2-1/2" (65 mm)	3" (75 mm)	4" (100 mm)	5" (125 mm)
8-12 / D-F	RC55	RC80	RC80	BP03	BP03	BP04	BP05	BP05	BP06	BP07	BP08
14-16 / G-H	RC80	BP03	BP03	BP03	BP04	BP05	BP05	BP06	BP06	BP07	BP08
18-20 / J-L	RC80	RC80	BP04	BP05	BP05	BP05	BP06	BP06	BP07	BP08	BP09

Injuries through 25%, but less than 75% of the body plies require both hole filling material and reinforced repair unit to be installed inside the tyre.

Repair Unit Name	Repair Unit Sizes		Ply Rating
	mm	Inches	
RC55	55	2-1/8	1
RC80	80	3-1/8	1
BP03	100	4	2
BP04	130	5-3/4	2
BP05	165	6-1/4	4

BP06	240	9-3/4	6
BP07	290	11-5/8	6
BP08	340	13-5/8	6
BP09	380	15-1/8	8
BP10	430	17	8

Note: Load, speed and highway application condition may affect section repairs. This selection repair chart is to be used only as a guide.

FCF-UK-0/00-00

VULCANIZING CEMENT

We offer a number of different cements; clear, blue, black and both flammable and non-flammable. The blue comes in a regular version and a heavy duty version. The regular blue version is very similar to the clear formulation, while the blue heavy duty version has a thicker viscosity. The viscosity has a slight characteristic change that gives the blue heavy duty version a little more tack and increased drying time due to solid increase from the amount of rubber used.

Regardless of solvent used, flammable vs non-flammable, the products are virtually the same except for the flammability issue. Some countries and some users require non-flammable formulation by regulatory law or company policy. Performance is the same, and bonding strength is the same between both cement solvents. Drying time may vary slightly but not significantly to notice. Weight of non-flammable is greater, but has no factor on performance. Both flammable and non-flammable cements are considered hazardous for shipping purpose.

The black cement is formulated without accelerators and can only be used in a heat cure system. It also has carbon black as part of the compounding for the cross linking of the molecular process of vulcanization.

Chemical Vulcanizing Cement

- Fast Drying.
- Brush top can.
- Non-ozone depleting chemicals.
- Cures with or without heat.
- Chemical activation.
- Available in clear, blue and black.
- Available both flammable and non-flammable formula.
- Reduces wait and allows for prompt repair.
- True vulcanizing cement that reacts with rubber facing gum to chemically bond repair units.

PART NUMBER	DESCRIPTION	CAN/CS
3-700	Chemical Vulcanizing Cement Flammable - 4 Oz	24
3-701	Chemical Vulcanizing Cement Flammable - 8 Oz	24
3-702	Chemical Vulcanizing Cement Flammable - 1 Qt	12
3-704	Chemical Vulcanizing Cement Flammable - 5 Gal	1
3-704-54	Chemical Vulcanizing Cement Flammable - 54 Gal	1
3-695	Chemical Vulcanizing Cement Flammable Blue - 4 Oz	24
3-698	Chemical Vulcanizing Cement Flammable Blue - 8 Oz	24
3-697	Chemical Vulcanizing Cement Flammable Blue - 1 Qt	12
3-690	Chemical Vulcanizing Cement Flammable Blue HD - 4 Oz	24
3-691	Chemical Vulcanizing Cement Flammable Blue HD - 8 Oz	24
3-692	Chemical Vulcanizing Cement Flammable Blue HD - 1 Qt	12
3-705	Chemical Vulcanizing Cement Non Flammable - 4 Oz	24
3-706	Chemical Vulcanizing Cement Non Flammable - 8 Oz	24
3-707	Chemical Vulcanizing Cement Non Flammable - 1 Qt	12
3-756	Chemical Vulcanizing Cement Non Flammable Blue - 4 Oz	24
3-757	Chemical Vulcanizing Cement Non Flammable Blue - 8 Oz	24
3-758	Chemical Vulcanizing Cement Non Flammable Blue - 1 Qt	12
3-759	Chemical Vulcanizing Cement Non Flammable Blue - 5 Gal	1
3-759-54	Chemical Vulcanizing Cement Non Flammable Blue - 54 Gal	1
3-724	Black Vulcanizing Cement Flammable Spray - 5 Gal	1
3-712	Black Vulcanizing Cement Flammable Brush - 1 Qt	12
3-713	Black Vulcanizing Cement Flammable Brush - 1 Gal	4
3-714	Black Vulcanizing Cement Flammable Brush - 5 Gal	1
3-714-54	Black Vulcanizing Cement Flammable Brush - 54 Gal	1
3-717	Black Vulcanizing Cement Non Flammable Brush - 1 Qt	12
3-718	Black Vulcanizing Cement Non Flammable Brush - 1 Gal	4
3-719	Black Vulcanizing Cement Non Flammable Brush - 5 Gal	1
3-719-54	Black Vulcanizing Cement Non Flammable Brush - 54 Gal	1
3-747	Black Vulcanizing Cement Flammable Brush X-Thick - 1 Qt	12
3-748	Black Vulcanizing Cement Flammable Brush X-Thick - 1 Gal	4
3-749	Black Vulcanizing Cement Flammable Brush X-Thick - 5 Gal	1



LIQUIDS AND SEALANTS

Inner Liner Sealant

- Seals exposed inner liner splices, over buffs or thin and porous areas of the liner.
- Seals the over buff around the repair unit.
- Prevents air migration in over buff area.
- Maintains integrity of tire repair.
- Flammable.

PART #	DESCRIPTION	CAN/CS
3-781	Liner Sealant - Black - Flammable - 8 Oz	24
3-782	Liner Sealant - Black - Flammable - 16 Oz	12
3-783	Liner Sealant - Black - Flammable - 1 Qt	12
3-786	Liner Sealant - Grey - Flammable - 8 Oz	24
3-785	Liner Sealant - Grey - Flammable - 16 Oz	12
3-788	Liner Sealant - Grey - Flammable - 1 Qt	12



Rim/Bead Sealant

- Forms airtight seal.
- Reduces bead leaks between the tire and rim.
- Apply to the beads of tubeless tires during mounting.
- Eliminates comebacks from bead leaks.
- Available regular and extra thick formula.
- Flammable.

PART NUMBER	DESCRIPTION	CAN/CS
3-762	Rim Sealant Flammable - 1 Qt	12
3-763	Rim Sealant Flammable - 1 Gal	4
3-764	Rim Sealant Flammable - 5 Gal	1
3-764-54	Rim Sealant Flammable - 54 Gal	1
3-772	Rim Sealant - extra thick -Flammable - 1 Qt	12
3-773	Rim Sealant - extra thick - Flammable - 1 Gal	4
3-774	Rim Sealant - extra thick -Flammable - 5 Gal	1
3-774-54	Rim Sealant - extra thick -Flammable - 54 Gal	1



Rubber Buffer/Solvent

- Specific formulation; multiple chemicals blended to effectively remove contamination from inner liner surface quickly and easily.
- Can be used as a pre-buff liner cleaner prior to buffing, and a repair cleaner to remove buff dust and other contaminants.
- Available both flammable and non-flammable.
- Removes silicone.
- Fast Drying.

PART NUMBER	DESCRIPTION	CAN/CS
3-731	Rubber Buffer 200 Non-Flammable - 8 Oz	24
3-732	Rubber Buffer 200 Non-Flammable - 1Qt	12
3-733	Rubber Buffer 200 Non-Flammable - 1 Gal	4
3-734	Rubber Buffer 200 Non-Flammable - 5 Gal	1
3-736A	Rubber Buffer 310 Flammable - 16 oz. Aerosol	12
3-736	Rubber Buffer 310 Flammable - 1 Qt	12
3-737	Rubber Buffer 310 Flammable - 1 Gal	4
3-738	Rubber Buffer 310 Flammable - 5 Gal	1
3-738-54	Rubber Buffer Flammable - 54 Gal	1



Bead Breaker

- Frees stubborn beads from wheel rim without special tools or machines.
- Eliminates need for heavy pounding and possible damage to tire.
- Easier on tire. Simplifies tire removal, even with mechanical tire changers.

PART NUMBER	DESCRIPTION	CAN/CS
3-752	Bead Breaker 510 Flammable - 1 Qt	12
3-753	Bead Breaker 510 Flammable - 1 Gal	4
3-754	Bead Breaker 510 Flammable - 5 Gal	1



KITS



PART NUMBER	DESCRIPTION	KITS/CASE
3-157	TRK-502	12
Contents: (1) metal t-handle split-eye needle, (1) metal t-handle smooth probe, (1) folding knife, (1) Allen wrench, (1) 2 oz jar of lube, (1) replacement needle and (25) 8" 12-strand orange repair inserts		



PART NUMBER	DESCRIPTION	KITS/CASE
3-156	TRK-501	12
Contents: (1) metal t-handle split-eye needle, (1) metal T-handle smooth probe, (1) folding knife, (1) Allen wrench, (1) 2 oz jar of lube, (1) replacement needle and (25) 4" 12-strand orange repair inserts		

PART NUMBER	DESCRIPTION	KITS/CASE
3-152	TRK-491	12
Contents: (1) 3" split-eye needle, (1) smooth probe, (1) 2 oz jar of lube, (1) equalizer hose and (25) 4" 12-strand black repair inserts		

PART NUMBER	DESCRIPTION	KITS/CASE
3-153	TRK-492	15
Contents: (1) Pistol grip handle, (1) 3" split eye needle, (1) smooth probe, (1) chemical vulc cement 4 oz, (1) 3 3/4" permaSeal 10-strand red poly 25/bundle		

PART NUMBER	DESCRIPTION	UNITS PER CASE	CTN SIZE
	2 oz Jar Lube Only - L1	50	
	BPK-108- Contents: (1) large split eye needle, (1) smooth probe, (4) 4" 12-strand black repair insert packs	12	

KITS



PART NUMBER	DESCRIPTION	KITS/CASE
3-151	TRK-490	12
Contents: (1) small split-eye needle, (1) smooth probe, (1) folding knife, and (5) 4" 12-strand black repair inserts		



PART NUMBER	DESCRIPTION	KITS/CASE
3-158	TRK-998	6
Contents: (1) 3" split-eye needle, 1 smooth probe, (1) 2 oz jar of lube and (50) 4" 12-strand orange repair inserts		

PART NUMBER	DESCRIPTION	KITS/CASE
3-162	BPK-106	12
Contents: (6) 4" 12-strand black insert packs		

PART NUMBER	DESCRIPTION	KITS/CASE
3-161	BPK-104	12
Contents: (1) small split eye needle, (1) smooth probe, (1) 4" 12-strand black repair insert pack		

TIRE REPAIR TOOLS

RASP/PROBE INJURY-CLEANING TOOL

PART #	DESCRIPTION	U/M
3-432	Plastic Pistol Grip Large handle barbed rasp	EA
3-403	Chrome Plated T-Handle Barbed rasp	EA
3-403R	Replacement Barbed Rasp	EA

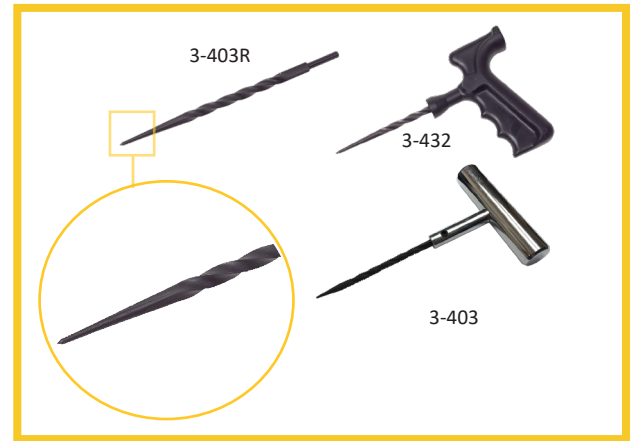

SPLIT-EYE INSERTING TOOL

PART #	DESCRIPTION	U/M
3-400	Chrome Plated T-Handle only	EA
3-401	Chrome Plate T-Handle with 3 1/2" Split-Eye Needle	EA
3-402	Chrome Plated T-Handle with 4 1/2" Split-Eye Needle	EA
3-425	Plastic Pistol Grip Large Handle 3 1/2" Split-Eye Needle	EA
3-426	Plastic Pistol Grip Large Handle 4 1/2" Handle Split-Eye Needle	EA

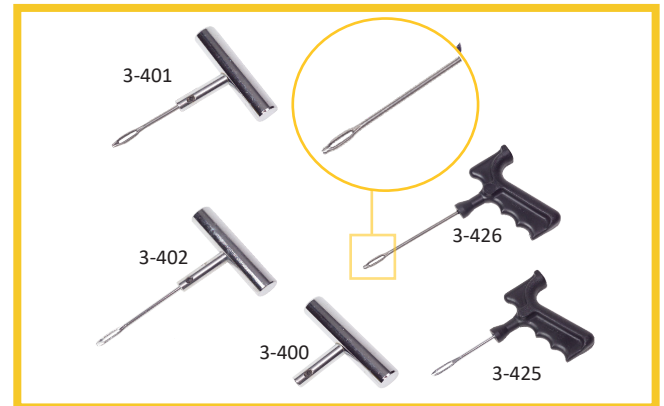

REPAIR TOOLS

PART #	DESCRIPTION	U/M
3-454	Ball bearing stitcher 1/8"	EA
3-457	Innerliner Scraper	EA
3-458	Economy buffer/stitcher combination	EA
3-459	Injury measuring tool	EA
3-460	Pointed awl	EA



TOOLS AND ACCESSORIES

MARKING CRAYONS

PART #	DESCRIPTION	QTY/ UM	U/M
3-481	White Crayon	12/BOX	EA
3-482	Yellow Crayon	12/BOX	EA
3-483	Carmel - Yellow Rubber Marking Crayon	12/BOX	EA
3-484	Carmel - White Rubber Marking Crayon	12/BOX	EA
3-485	Carmel - Yellow Paint Marker	12/BOX	EA
3-486	Carmel - White Paint Marker	12/BOX	EA
3-487	Carmel - Yellow Paint Crayon	12/BOX	EA
3-488	Carmel - White Paint Crayon	12/BOX	EA

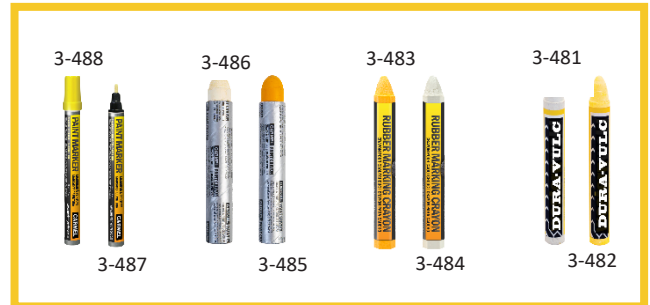

BUFFING TOOLS & ADAPTERS

PART #	DESCRIPTION	U/M
3-464	Black Buffing Stone 36 grit	EA
3-465	2" Tungsten Carbide Buffing Wheel	EA
3-466	2 1/2" Tungsten Carbide Buffing Wheel	EA
3-467	2 1/2" Carbide Buffing Wheel 60 grit	EA
3-468	Wire Wheel Brush	EA
3-470	1/4" Drill Arbor for BC20, BC25, or WB1	EA
3-471	Quick change adapter 3/8" x 5/8" long	EA
3-472	Quick change adapter 3/8" x 1" long	EA
3-473	Quick change adapter 1/8" shank	EA
3-474	Quick change adapter 7/32" shank	EA
3-475	Quick change adapter 5/16" shank	EA
3-476	Quick change adapter 3/16" shank	EA



CARBIDE CUTTERS

PART #	DESCRIPTION	U/M
3-651	Carbide Cutter for injuries up to 3mm - ECC03	EA
3-652	Carbide Cutter for injuries up to 4.5mm - ECC045	EA
3-653	Carbide Cutter for injuries up to 6mm (3") - ECC06	EA
3-654	Carbide Cutter for injuries up to 6mm (2") - ECC06	EA
3-655	Carbide Cutter for injuries up to 8mm - ECC08	EA
3-657	Carbide Cutter for injuries up to 10mm - ECC10	EA

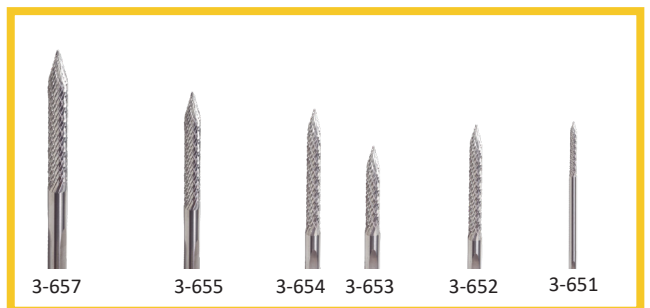

PATCH COMPARISONS

	PRODUCT CODE	TECH TIRE REPAIRS	REMA TIP TOP	PATCH RUBBER	VIPAL	GROUP 31	MARUNI
Bias Repair Units	UP 55	BP-0**		CX-1*	VD-1	CP 0	
	UP 65	BP-1**	PN-1	CX-2*		CP 1	
	UP 85	BP-2**	PN-2	CX DC-3-2	VD-2	CP 2	GBT-02
	BP 03	BP-3	PN-3	CX DC-4-2	VD-3	CP 3	GBT-03
	BP 04 H	BP-4**		CX DC 5-3***	VD-4	CP 4	GBT-04
	BP 05	BP-5	PN-5*	CX DC7-3****	VD-5*	CP5	GBT-05
	BP 06	BP-6	PN-6*	CX DC-9-6*	VD-6*	CP 6	GBT-06
	BP 07	BP-7	PN-7**	CX DC-12-6	VD-7	CP7	
	BP 08					CP 8	
	BP 09	BP-8	PN-8		VD-8	CP 9	
	BP 10	BP-9	PN-9*	CX DC 16-8	VD-9*	CP 10	
Radial Repair Units	RD 110	CT-10 HD**				11-808	GNR-08
	RD 110 R	CT-10**	RAD-110*	BUL DC-10**	RAC-10**	11-810	GNR-10
	RD 112	CT-12*	RAD-112*	BUL DC-12*	RAC-12*	11-812	GNR-18
	RD 114	CT-14*		BUL DC-14*	RAC-14*	11-814	
	RD 120	CT-20*	RAD-120*	BUL DC-20*	RAC-20*	11-820	GNR-12
	RD 122	CT-22*	RAD-122*	BUL DC-22*	RAC-22*	11-822	GNR-22
	RD 124	CT-24*	RAD-124*	BUL DC-24*	RAC-24**	11-824	GNR-25
	RD 126	CT-26*		BUL DC-26*	RAC-26	11-826	
	RD 128					11-828	
	RD 133	CT-33	RAD-125**	BUL DC-33**		11-825	
	RD 135	CT-35		BUL DC-35**		11-835	
	RD 140	CT-40	RAD-140*	BUL DC-40**	RAC-40	11-840	GNR-40
	RD 142	CT-42*	RAD-142	BUL DC-42	RAC-42***	11-842	GNR-42
	RD 144	CT-44*	RAD-144	BUL DC-44	RAC-44**	11-844	
RD 146		RAD-146**		RAC-46**	N/A		
All Purpose Repair Units	AP 045 S R *	Sq All Purpose Cat # 115	UP-6	UP-1		11-115B	
	AP 055 S R *	Sq All Purpose Cat # 116	UP-4-5P	YP-2	VF-6*	11-116B	
	AP S 75 R *						
Stem & Patch Combo	SP 03	Uni-Seal Cat # 249W	A-6 Minicombi	CAT 14040		N/A	
	SP 06		B8-MC Mini-combi		MC-6	13-673C	PLUG-PATCH3505
	SP 08	Uni-Seal Cat # 251UL		CAT 14042	MC-8	13-674C	PLUG-PATCH5609
	SP 10	Radial Seal 291/38				N/A	
Stem with Lead Wire	SI 06		RS-8		VIPSTEM 6	13-621C	
	SI 08		RS-10	CAT 14570	VIPSTEM 8	13-622C	
	SI 10			CAT 14571	VIPSTEM 10	13-623C	
Tube Repair Circle	CT 25	Tiny Round	B-0	PR-0	RBM-01	11-000	
	CT 40	Mini Round*	B-1	PR-1	R-01	11-001	
	CT 45	Small Round	B-2	PR-2	R-02**	11-001	
	CT 55	Medium Round**	B-3	PR-3	R-03**	11-002	
	CT 75	Large Round**		PR-4	R-04**	11-003	
	CT 100	Maxi Round		PR-5*	R-05	N/A	
Tube Repair Oval	OT 40	Mini Oval**				11-004	
	OT 75	Small Oval	B-7	PR-7	R-300	11-005	
	OT 100	Medium Oval	B-7A*	PR7A	R-301	11-006	

* patch is slightly bigger ** patch is slightly smaller *** patch is 1 ply less **** patch is 1 ply more

*Please note; chart indicates closest comparable size and fit. Please confirm size required prior to ordering.

NOTES



PART NUMBER		DESCRIPTION
33223	T23A	Truck Lock Ring Remover
34644	T45A	Style Tubeless Tire Iron
35440		Blue Cobra
35595		27" TC95 Heavy-Duty Truck 4-Way
34645	T45A	Tubeless Tire Iron
34647	T45HD	H.D. Tubeless Tire Iron
39810	T43D	Heavy Duty tire lever
39808	T44	Tire mount/demount lever
33219	T19A	30" Tire Iron
34747	T46A	36 IN. Tire Iron
32508	TR98	Double-End Truck Wrenches
32318	TR5	Truck Wrench Handle
35329	T11E	Bead Breaking Wedge
35695	T95	H.D. 4-way wrench- truck
35657	T57	23" 4-way lug wrench
35926	T26B	Heavy Duty Bead Breaker
31444		Mega Airblast Bead Seating Tool
31567	T67	Pro Wheel Cover Puller/Replacer
36010	T110	5-Bar SuperMagnum



PART NUMBER		DESCRIPTION
29980		Saver 35329 Starter Kit, 12 T11E Bead Breaking Wedg Replacement Valves
35429		Bead breaking wedge
34555		Sharkfin

For more information, www.kentool.com



Dreumex USA Inc. is a leading manufacturer of heavy-duty and out-of-home hand cleaners, hand care products and disinfecting wipes. The extensive range of products provides a solution for every situation so that your hands are also clean and healthy. Their product line consists of several types of gel and lotion hand cleaners, hand soaps, hand cleaning towels, foam soaps and innovative dispensing concepts.

PART NUMBER	DESCRIPTION
3-3510	Dreumex Pumiced Grime Grabber
3-1412	Dreumex Pumiced Grime Grabber
11-2112	Dreumex Citrus Lotion 21 fl. oz
21-9060C	Power Wipes Multipurpose Towels
G25218	Dreumex Pumice Orange Lotion
2-4560	Dreumex Grime Grabber
2-1412	Dreumex Grime Grabber- tub 14 o.z.
31-9060C	Ultra Power Wipes Multipurpose Scrubber
0-5000G	Dispenser-Mate 5000 Reservoir Dispenser
G25116	Dreumex Pumice Orange Lotion, 15 oz bottle

For more information, www.dreumex.com



ESCO

THE ORIGINAL INNOVATORS



PART NUMBER	DESCRIPTION
10301	Ram, Hydraulic, 10 Ton, 2-1/8" Stroke
10302	Ram, Hydraulic, 10 Ton, 4-1/8" Stroke
10303	Ram, Hydraulic, 10 Ton, 6-1/8" Stroke
10304	Ram, Hydraulic, 10 Ton, 8" Stroke
10305	Ram, Hydraulic, 10 Ton, 10-1/8" Stroke
10306	Ram, Hydraulic, 30 Ton, 2-7/16" Stroke
PART NUMBER	
10300	Jack, 100 Ton Lightweight Aluminum With Shut Off Valve
10312	Jack, 55 Ton Lightweight Aluminum With Shut Off Valve And Base Plate, 6" Stroke
10508	Hand Operated 1 Quart Hydraulic Pump
10592	Pump, Air/Hydraulic, 5 Quart
20408-N	Demount Tool, Pneu-Tek Universal Impact Driven Demount System
20406-N	Bead Keepers
90518-100-KIT	ESC100 Truck Tire Demount/Mount Kit
PART NUMBER	
90450	Tire Spreader, Turntable Style
90451	Tire Spreader, Manual
90452	Tire Spreader, Handheld, Portable Air Operated
90453	Tire Spreader, Pneumatic Passenger And Light Truck
90455	Tire Spreader, Turntable Style w/ Mount Base



PART NUMBER	DESCRIPTION
10100	Bead Breaker Head, Giant Tire
10101	Bead Breaker Head, "Combi" With Conversion Kit
10102	Bead Breaker Head, Maxi"
10107	Bead Breaker Head, Euro Style
70160	Bead Breaker, Manual



For more information, www.esco.net



TM



WWW.DURA-VULC.COM



FACEBOOK.COM/DORIANDRAKEINTL



TWITTER.COM/DORIANDRAKEINTL



LINKEDIN.COM/COMPANY/DORIAN-DRAKE-INTERNATIONAL



DURA-VULC@DORIANDRAKE.COM



+1 (914) 697-9800

2 WESTCHESTER PARK DRIVE, WHITE PLAINS, NEW YORK, 10604, USA

© 2019 DORIAN DRAKE INTERNATIONAL, INC. DURA-VULC® IS A REGISTERED CTM